

A UAV-Assisted Handover Scheme for Coverage Maximization against 5G Coverage Holes

Hyeonah Jung
 Computer Science & Engineering
 Sungkyunkwan University
 Suwon, Republic of Korea
 hyeonah214@skku.edu

Eshita Rastogi
 Computer Science & Engineering
 Sungkyunkwan University
 Suwon, Republic of Korea
 eshita@skku.edu

Jaehoon (Paul) Jeong
 Computer Science & Engineering
 Sungkyunkwan University
 Suwon, Republic of Korea
 pauljeong@skku.edu

Abstract—The Handover (HO) problem is widely explored by the research industry. In the dense traffic, the vehicles move at a lower speed, which means the vehicles will spend more time in the coverage holes. The absence of a communication link from the Next Generation NodeB (gNB) will degrade the Quality of Service (QoS) requirement of users. This motivates us to propose Unmanned Aerial Vehicles (UAVs) (e.g., drones) as temporary base stations to serve the traffic of User Equipments (UEs) in peak hour conditions. To overcome the HO delay, we propose a machine learning-based proactive HO scheme. In this paper, we train a Long Short-Term Memory (LSTM) model using Reference Signal Received Power (RSRP) values to predict and optimize HO decisions. Experimental results show that a UAV-assisted HO strategy can significantly enhance network performance in terms of the reduction of both Ping-Pong Rate and End-to-End Delay as performance metrics.

I. INTRODUCTION

Vehicles are moving on the highway, and experience frequent Handovers (HO). An increase in the frequency of HO and its interruption time disrupts the connectivity and results in the degradation of users' Quality of Service (QoS) performance [1], [2]. The dense deployment of Next Generation NodeB (gNBs) on the highways is cost-ineffective, as the high traffic density is only limited to peak hours conditions. The deployment of UAVs as aerial Base Stations (BS) can provide cost-effective wireless communication to users. Unmanned Aerial Vehicle (UAVs) providing Line-of-Sight (LoS) communication, is likely to deliver reliable and on-demand wireless communication to the desired area [3]. The UAV communication mainly includes UAV mobile relaying, UAV small cells, and UAV-enabled traffic offloading [4].

Conventional HO in 5G consists of three phases such as preparation, execution, and completion, as shown in Fig. 1. This conventional HO procedure takes a substantial amount of time increasing the HO interruption time (HIT). The increase in HIT is directly related to users' QoS [1]. Additionally, the directional mmWave imposes several challenges, like coverage blindness, in HO procedure. The candidate gNB of HO vehicles should be proactively prepared about the beam pair to avoid the exhaustive beam searching procedure, which is likely to increase HIT and degrade QoS performance.

Authors in [5], [6] propose a Machine Learning (ML)-based model to predict the Reference Signal Received Power (RSRP)

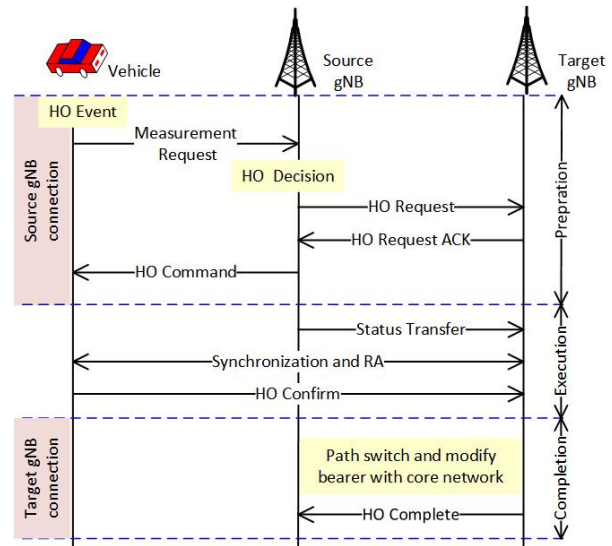

Fig. 1: Handover procedure

of the access point to analyze the HO trigger decision. Authors in [7] propose an artificial neural network-based HO protocol that takes both user and network satisfaction into account by considering both QoS and Quality of Experience (QoE) during and after HO. Authors in [8] proposes federated learning-based proactive HO to reduce the number of unnecessary HOs and HO delays simultaneously. Authors in [9] propose an ML-based HO in both sub-6GHz and mmWave integrated vehicular networks. Authors in [10] proposed an LSTM-based HO scheme for UEs in 5G networks. They presented only a concept of LSTM-based HO for proactive HO management, but did not prove the concept through either simulation or experiment. Additionally, before using LSTM, we reduced RSRP noise by employing a Kalman Filter (KF) for training.

The abovementioned work considers full coverage of the highway by the gNB, which is impractical owing to the deployment cost. But the highways are crowded only during peak traffic conditions, so serving the traffic with temporary BSs can reduce the hefty installation cost. Additionally, the existing work does not consider the relevance of the beam-forming procedure, which is crucial in mmWaves bands. The

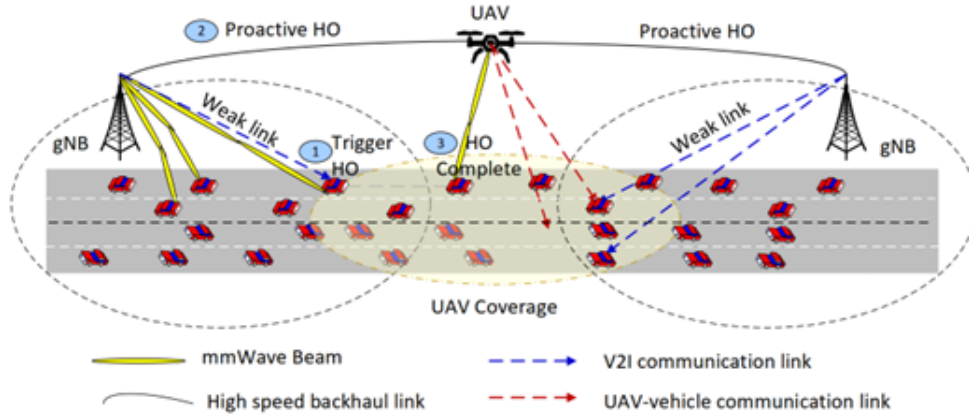

Fig. 2: A system model for proactive handover with UAV as an aerial base station

beam searching procedure will increase the complexity of the HO process, especially in moderate user density to high user density [11]. The candidate gNB of the HO vehicle should be proactively prepared, having information on the suitable beam pair to align with the vehicle coming towards it. Therefore, this research focuses on three major directions:

- Use of aerial BSs (eg. UAVs like drones) to deal with coverage holes in the highways.
- Proposal of proactive handover to reduce unnecessary HOs, HO delay, and throughput of the users
- Consideration of the relevance of beamforming to avoid coverage blindness due to directional beam in mmWaves band.

The rest of the paper is organized as follows: Section 2 describes the preliminary study which includes a discussion on conventional HO procedure, KF, and LSTM. Section 3 describes the HO problem in vehicular communications and our proposed idea. The simulation setting and simulation results are described in Section 4 followed by the conclusion in Section 5.

II. PRELIMINARY STUDY

A. Conventional Handover Procedure

As shown in Fig. 1, a vehicle as a UE establishes a connection with a Target gNB (T-gNB), including synchronization and Random Access (RA), during the execution phase after disengaging from its Source gNB (S-gNB). The S-gNB also sends a status transfer message to the T-gNB, including the downlink and uplink sequence numbers, while forwarding the UE's downlink data to it. The fundamental network entities change their pathways and alter the bearer configurations throughout the completion phase. The UE context is then released in the S-eNB by the T-eNB by sending a HO complete (HO Complete) message to the S-eNB. However, the HO operation may not succeed if the HO control messages are not sent or if a Radio Link Failure (RLF) takes place while it is being performed. Compared to the other phases, the preparation phase has a higher likelihood of the UE experiencing numerous HO message delivery failures or

RLF since it is conducted when the S-eNB signal quality is poor and T-eNB interference is significant. Since this is the case, the basic HO's preparation phase is when it is most vulnerable. Additionally, due to the mmWave bands' unusually high shadowing sensitivity, HO Failure (HOF) occurs more frequently in this instance. This is because the connection between the UE and the serving cell is more easily broken, so HO message delivery fails regardless of the target cell's connectivity.

B. Kalman Filtering

High noise levels are most likely present in the received RSRP measurement. Therefore, filtering RSRP readings is essential to obtaining exact information. In our system, RSRP data is preprocessed using a KF before being sent to an ML classifier. The raw RSRP data is first smoothed using a KF, and then it is supplied to the ML algorithm for HO prediction. The KF is considered an optimal solution for many signal processing and prediction tasks that have linear system models with Gaussian noise. The KF algorithm consists of two stages: Prediction and update procedure to obtain the state of the system [12], [13]. The system can be described as

$$S_{t+1} = \Phi S_t + N_t, \quad (1)$$

where S_t is the state vector of the system at the time step t , Φ is the state transition matrix of the system from time step t to $t + 1$, and N_t is the white noise that has a known co-variance matrix Q . The measurement equation of the system can be described as follows:

$$M_t = H S_t + V_t, \quad (2)$$

where M_t is a measurement state vector of s at time t , H is the connection matrix for the measurement, and V_t is a measurement error with the known co-variance matrix as R . The error co-variance Q of the system and R of the measurement are given as $Q = [U_t U_t^T]$ and $R = [V_t V_t^T]$, respectively. The state update equation is given by

$$\hat{S}_t = \hat{S}'_t + K_t (M_t - H S'_t), \quad (3)$$

where \hat{S}_t is an estimate of the system state S_t and the prior estimate of \hat{S}'_t , and K_t is the Kalman gain obtained by the following equation:

$$K_t = P'_t H^T (H P'_t H^T + R)^{-1}. \quad (4)$$

The mean square error (MSE) co-variance \hat{P}'_t of the system can be given by

$$\hat{P}_t = (I - K_t H) \hat{P}'_t, \quad (5)$$

where I is the identity matrix, and the prior MSE co-variance \hat{P}'_t is updated by

$$P'_{t+1} = \Phi P_t \Phi' + Q, \quad (6)$$

and the prior system state for next step is given by

$$S'_{t+1} = \Phi S_t. \quad (7)$$

Using the aforementioned prediction and update procedure, we can filter noises to obtain the true system state.

C. LSTM

The long-term storage capability of LSTM [14] allows it to learn the long-term dependencies within a sequence. At the time slot t , an LSTM cell has an input layer X_t and an output layer Y_t . In this instance, the dataset is Xt and the class labels are Yt . LSTM consists of a memory cell, an input gate I_t , an output gate O_t , and a forget gate F_t where the update equations are given by Equations (8), (9), and (10). The gates [15] the flow of information into and out of the memory cell, which is where information is stored.

$$F_t = \alpha(W_{fx} X_t + W_{fh} h_{t-1} + b_f), \quad (8)$$

$$I_t = \alpha(W_{ix} X_t + W_{ih} h_{t-1} + b_i), \quad (9)$$

$$O_t = \alpha(W_{ox} X_t + W_{oh} h_{t-1} + b_o). \quad (10)$$

Using Equations (8), (9), and (10), the cell state C_t and the output Y_t are updated by the following equations:

$$C_t = F_t \otimes C_{t-1} + I_t \otimes \tanh(W_{cx} d_t + W_{ch} Y_{t-1} + b_c), \quad (11)$$

$$Y_t = O_t \otimes C_t, \quad (12)$$

where W denotes the weight matrix, b denotes the bias, and the operator of \otimes represents an element-wise multiplication of the vectors.

III. HANDOVER PROBLEM IN VEHICULAR NETWORK

A. System Model

We consider a bidirectional highway network comprising of gNBs and UAVs, where UAV serves as a temporary BS. The mmWave-enabled gNBs are deployed along the roadside, which partially cover the road network, i.e., there exist some coverage holes on the highway. These coverage holes on the highway can be served by UAVs, instead of installing more gNBs, which is cost-ineffective, as shown by Fig. 2. We consider a directional antenna for both gNBs and UAVs. The mutual interference between the UAVs and the gNBs can be

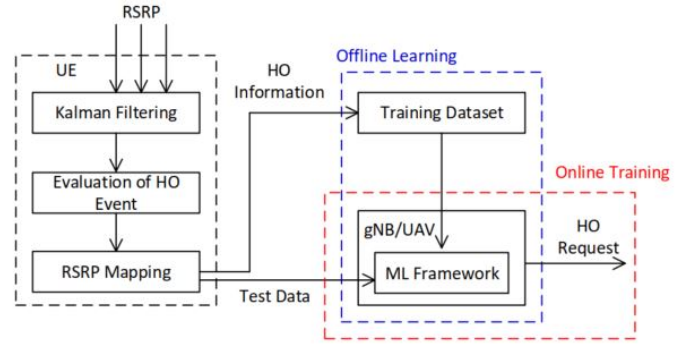

Fig. 3: Machine learning model for proactive handover

eliminated by considering orthogonal spectrum sharing. Fig. 2 shows the triggering point and completions of proactive HO. In the peak traffic condition, i.e., the dense vehicular traffic scenario, the arrival of the vehicles is assumed to follow Poisson distribution. The vehicles periodically report their position, velocity, and channel state information (CSI) to their serving gNBs.

B. Proposed ML-based Proactive Handover

In dense traffic, vehicles move at a lower speed. This means that the vehicles will spend more time in the coverage holes. The absence of a communication link from the gNB will degrade the QoS requirement of the users. This motivates us to propose UAV as a temporary BS to serve the traffic in peak hour conditions as shown in Fig. 2. To overcome the HO delay, we propose ML-based proactive HO. The major benefit of considering ML-based proactive HO is that it eliminates HO execution and completion phase, thus reducing the HO time.

The RSRP information collected from the vehicles is filtered to reduce noise, mitigate fading and shadowing effects, and obtain precise information. We employ KF to smooth the RSRP signals. The smoothed RSRP data is prepared for the next step of the proposed method. The filtered time series of RSRP measurement includes the pattern of RSRP drop and rise between the Source-gNB/UAV and Target-gNB/UAV, which is used to train the ML model. The decision whether to initiate HO or not, is modeled as a Recurrent Neural Network (RNN) and is used to solve the classification problem [16]. The ML algorithm is performed in two steps:

- **Offline phase:** The smoothed RSRP dataset is used to train the ML algorithm.
- **Online phase:** The RSRP data of the real-time user is measured and then compared with the pre-recorded training data.

With RSRP information, the ML algorithm can also estimate vehicle positions. Based on the position information, when the vehicle requests the HO, the candidate BS will be pre-activated to sweep a beam toward the HO vehicle [17]. The RSRP information is fed to the trained ML algorithms which can predict the need of HO online. Fig. 3. demonstrated the step-by-step implementation of the proposed ML-based algorithm.

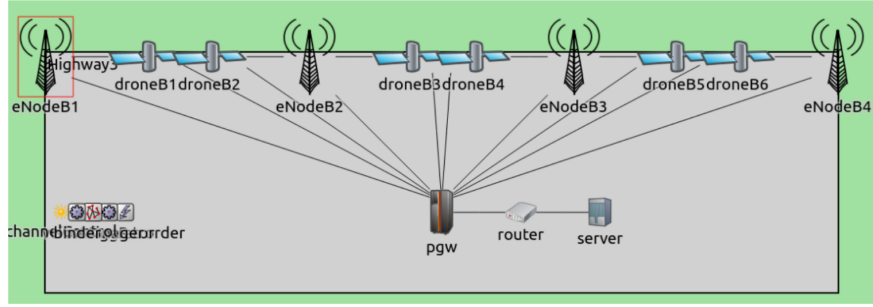

Fig. 4: Simulation setup

Overall, our proposed idea jointly addresses the beamforming and proactive HO problem. The learning-based proactive HO and efficient beamforming will ensure smooth HO and maintain the QoS requirements of the end user.

IV. PERFORMANCE EVALUATION AND RESULTS

In this section, we describe the simulation setup followed by the experimental results.

A. Simulation Setup

The dataset employed in this paper was collected from an open-source framework for running a computer network simulator called OMNeT++ [18], which support the simulation of wired and wireless communications in vehicular networks, and a road network simulator called SUMO [19], which supports microscopic road traffic simulation [20]. Simu5G [21] is a 5G network simulator built on top of OMNeT++ for 5G radio access networks (RANs) and 5G core networks with the Simu5G protocol stack [22]. SUMO is a geographic-based traffic simulator responsible for vehicle mobility in road networks. An additional module for the UAV was built on top of the existing module. Additionally, the vehicle used the Veins for vehicular communications in OMNeT++ [23]. Fig. 4 shows the simulation setup for implementing proactive HO in 5G and UAV-assisted cellular networks, intending to improve the QoS requirements of the end users. The simulation parameters can be found in Table I.

In this work, we consider a highway road that consists of a total of four lanes, with two lanes in one direction and the possibility of making U-turns. The signal strength of the gNB is considered 46 dBm, and the signal strength of the drone is 23 dBm. Measurements were conducted for 4,000 vehicles over a period of 48 hours. Vehicles are generated using Gaussian distribution [24]. The signal strength was observed as vehicles moved from one gNB to another gNB. Additionally, RSRP values were denoised using the KF. In summary, the dataset was gathered from the received signals of gNBs and drones, and the data was pre-processed for the creation of an LSTM model.

B. Performance Metrics

- 1) The average **Ping-Pong Rate** is calculated as the total number of movements that are recognized as Ping-

TABLE I: Simulation parameters

Simulation Parameters	Value
Number of gNBs	4
Number of drones	6
gNB height	30 m
Drone height	60 m
gNB Tx power	46 dBm
drone Tx power	23 dBm
Average velocity	20 m/s
Road	10 kms
Number of cars	100

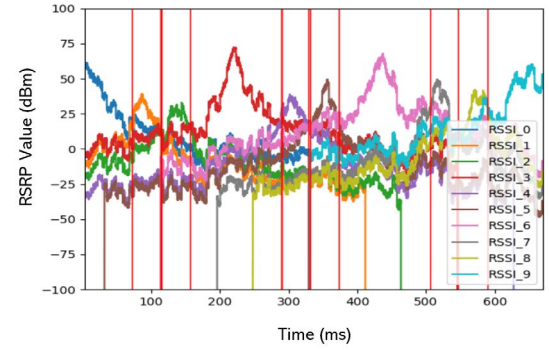

Fig. 5: Training data as input to the ML model

Pong patterns divided by the overall number of movements. It is a significant metric that is used to analyze mobility data, particularly in the context of wireless communication, mobility-related research, and network technologies.

- 2) **End-to-End Delay** is a critical performance metric that is used to calculate the delay experienced by the vehicle in moving from the coverage of one gNB to another gNB.

C. Simulation Results

Fig. 5 represents the RSRP data reported by the vehicle to the base station after every 100 ms. The RSRP data here is filtered using the KF to reduce noise, mitigate fading and shadowing effects, and obtain precise information. Fig. 6 shows that the predicted RSRP value using LSTM closely matches the filtered value RSRP value using the KF.

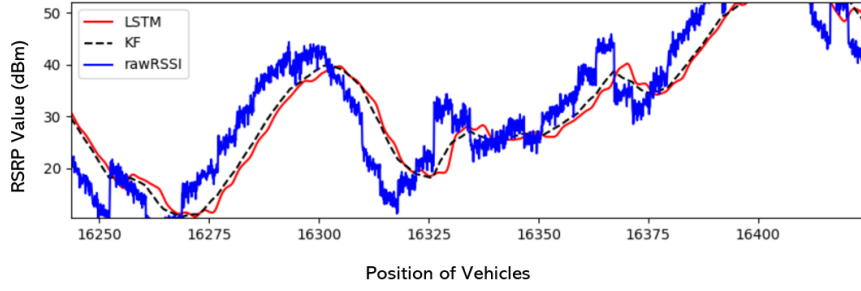

Fig. 6: Comparison of the predicted RSRP values using LSTM and KF

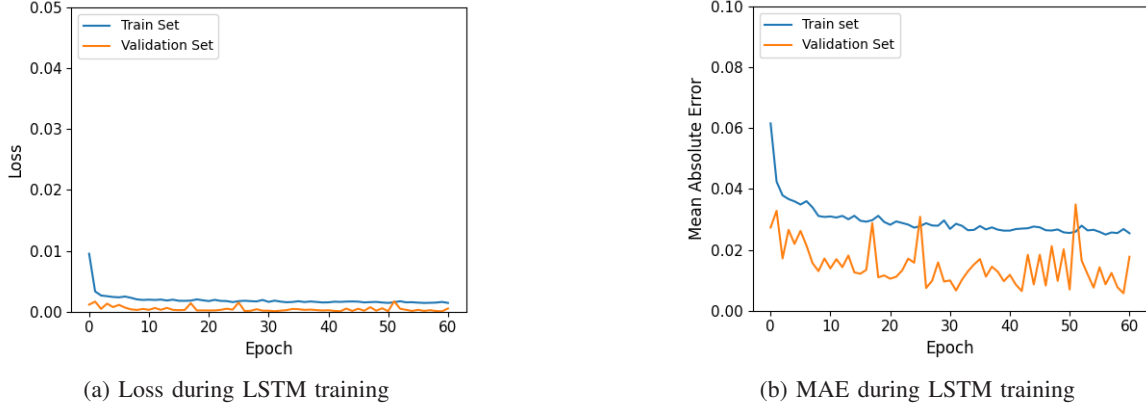

Fig. 7: Loss and MAE of the LSTM model during the training process

Fig. 7a shows the training process of the model for a total of 54 epochs, using the Early Stopping feature. The total training time was approximately 735.63 seconds. As a final outcome of the training, the model's loss value reached 0.00166. This signifies that the model is very effective as the mean squared error between the actual and predicted values is very close. Fig. 7b shows the Mean Absolute Error (MAE) was 0.02686, indicating that the predicted values differ from the actual values by an average of about 0.02686.

Fig. 8 shows the comparison between Conventional HO and HO with KF and LSTM for Ping-Pong Rate and End-to-End Delay. Regarding the Ping-Pong Rate in Fig. 8a, the Conventional HO demonstrated an average rate of 21.5 %, while the HO with the KF and LSTM achieved a significantly improved average rate of 1.2 %. The substantial reduction in the Ping-Pong Rate with our proposed approach indicates a remarkable reduction in unnecessary HO events.

In terms of End-to-End Delay in Fig. 8b, the results reveal that the Conventional HO had an average delay of 790 ms, whereas the HO with the KF and LSTM achieved a lower average delay of 585.5 ms. The improved End-to-End Delay observed with HO using KF and LSTM can be attributed to two primary factors. This is because the LSTM model was able to learn the long-term dependencies in the data, which allowed it to predict future HO events more accurately. This resulted in fewer unnecessary HOs, which further reduced the End-to-End Delay.

The combined effect of reduced RSRP noise and LSTM-based prediction resulted in a more efficient and reliable HO mechanism with the HO using the KF and LSTM, as reflected in the results of both the Ping-Pong Rate and End-to-End Delay. These simulation outcomes demonstrate the superiority of our proposed HO with the KF and LSTM approach over the Conventional HO. The integration of KF and LSTM offers promising solutions for enhancing the performance of handover operations in vehicular networks.

V. CONCLUSION

In this paper, we evaluate the HO performance in 5G vehicular communications with the assistance of drones. Here we propose an ML-based model which consists of two phases, such as an offline training phase and an online phase for prediction in real time. The RSRP information is fed to the trained ML algorithms which can predict the need of HO online. Our proposed idea jointly addresses the beamforming and proactive HO problem. The learning-based proactive HO and efficient beamforming will ensure smooth HO and maintain the QoS requirements of the UEs as end users. We evaluate the performance of the proposed HO scheme and the conventional HO scheme based on the Ping-Pong Rate and End-to-End Delay. As future work, we will enhance our proactive HO scheme in IP-based vehicular networks with the efficient combination of a mobility management scheme

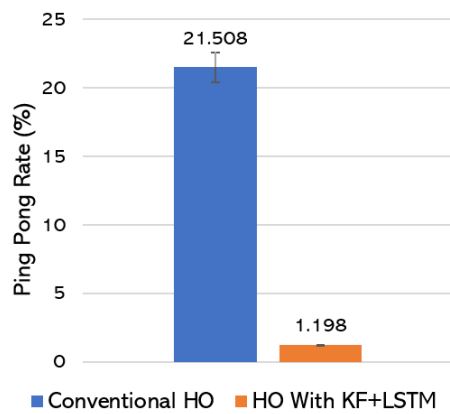

(a) Ping-Pong Rate Comparison

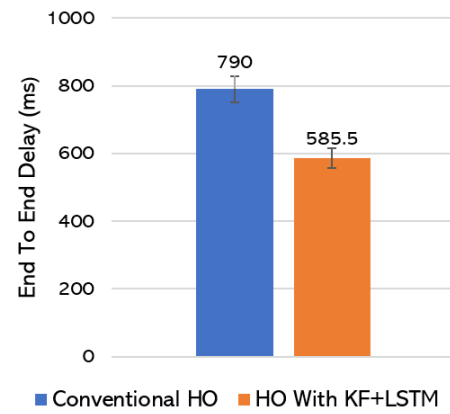

(b) End-to-End Delay Comparison

Fig. 8: Performance comparison between Conventional HO and HO with KF + LSTM

such as Proxy Mobile IPv6 (PMIPv6) and Distributed Mobility Management (DMM).

ACKNOWLEDGMENTS

This work was supported by the National Research Foundation of Korea (NRF) grant funded by the Korea government, Ministry of Science and ICT (MSIT) (No. 2023R1A2C2002990). This work was supported in part by the Institute of Information & Communications Technology Planning & Evaluation (IITP) grant funded by the Korea MSIT (No. 2022-0-01015, Development of Candidate Element Technology for Intelligent 6G Mobile Core Network). Note that Jaehoon (Paul) Jeong is the corresponding author.

REFERENCES

- [1] C. Lee, H. Cho, S. Song, and J.-M. Chung, "Prediction-based conditional handover for 5g mm-wave networks: A deep-learning approach," *IEEE Vehicular Technology Magazine*, vol. 15, no. 1, pp. 54–62, 2020.
- [2] Y. Li, B. Cao, and C. Wang, "Handover schemes in heterogeneous lte networks: challenges and opportunities," *IEEE Wireless Communications*, vol. 23, no. 2, pp. 112–117, 2016.
- [3] W. Shi, H. Zhou, J. Li, W. Xu, N. Zhang, and X. Shen, "Drone assisted vehicular networks: Architecture, challenges and opportunities," *IEEE Network*, vol. 32, no. 3, pp. 130–137, 2018.
- [4] M. Mozaffari, W. Saad, M. Bennis, Y.-H. Nam, and M. Debbah, "A tutorial on uavs for wireless networks: Applications, challenges, and open problems," *IEEE communications surveys & tutorials*, vol. 21, no. 3, pp. 2334–2360, 2019.
- [5] N. Aljeri and A. Boukerche, "A two-tier machine learning-based handover management scheme for intelligent vehicular networks," *Ad Hoc Networks*, vol. 94, p. 101930, 2019.
- [6] —, "An efficient handover trigger scheme for vehicular networks using recurrent neural networks," in *Proceedings of the 15th ACM International Symposium on QoS and Security for Wireless and Mobile Networks*, 2019, pp. 85–91.
- [7] V. O. Nyangaresi and A. J. Rodrigues, "Efficient handover protocol for 5g and beyond networks," *Computers & Security*, vol. 113, p. 102546, 2022.
- [8] K. Qi, T. Liu, and C. Yang, "Federated learning based proactive handover in millimeter-wave vehicular networks," in *2020 15th IEEE International Conference on Signal Processing (ICSP)*, vol. 1. IEEE, 2020, pp. 401–406.
- [9] L. Yan, H. Ding, L. Zhang, J. Liu, X. Fang, Y. Fang, M. Xiao, and X. Huang, "Machine learning-based handovers for sub-6 ghz and mmwave integrated vehicular networks," *IEEE Transactions on Wireless Communications*, vol. 18, no. 10, pp. 4873–4885, 2019.
- [10] Y. Jang, S. M. Raza, M. Kim, and H. Choo, "Proactive handover management based on rssi prediction for 5g network," in *KIPS Fall Conference*, vol. 27, no. 2. Korea Information Processing Society (KIPS), 2020, pp. 186–188.
- [11] S. Khosravi, H. Shokri-Ghadikolaei, and M. Petrova, "Learning-based handover in mobile millimeter-wave networks," *IEEE Transactions on Cognitive Communications and Networking*, vol. 7, no. 2, pp. 663–674, 2020.
- [12] Y. Shen, B. Hwang, and J. P. Jeong, "Particle filtering-based indoor positioning system for beacon tag tracking," *IEEE Access*, vol. 8, pp. 226 445–226 460, 2020.
- [13] F. Govaers, *Introduction and Implementations of the Kalman Filter*. BoD—Books on Demand, 2019.
- [14] A. Graves and A. Graves, "Long short-term memory," *Supervised sequence labelling with recurrent neural networks*, pp. 37–45, 2012.
- [15] S. Moon, H. Kim, and I. Hwang, "Deep learning-based channel estimation and tracking for millimeter-wave vehicular communications," *Journal of Communications and Networks*, vol. 22, no. 3, pp. 177–184, 2020.
- [16] R. Zhohov, A. Palaios, H. Rydén, R. Moosavi, and J. Berglund, "Reducing latency: Improving handover procedure using machine learning," in *2021 IEEE 93rd Vehicular Technology Conference (VTC2021-Spring)*. IEEE, 2021, pp. 1–5.
- [17] P. Zhou, X. Fang, Y. Fang, Y. Long, R. He, and X. Han, "Enhanced random access and beam training for millimeter wave wireless local networks with high user density," *IEEE Transactions on Wireless Communications*, vol. 16, no. 12, pp. 7760–7773, 2017.
- [18] OMNeT++, "Discrete Event Simulator," <https://omnetpp.org/>.
- [19] SUMO, "Simulation of Urban Mobility," <https://sumo.dlr.de/docs/index.html>.
- [20] S. Toufga, S. Abdellatif, P. Owezarski, T. Villemur, and D. Relizani, "Effective prediction of v2i link lifetime and vehicle's next cell for software defined vehicular networks: A machine learning approach," in *2019 IEEE Vehicular Networking Conference (VNC)*. IEEE, 2019, pp. 1–8.
- [21] Simu5G, "5G New Radio User Plane Simulation Model for INET OMNeT++," <http://simu5g.org/>.
- [22] G. Nardini, D. Sabella, G. Stea, P. Thakkar, and A. Virdis, "Simu5g—an omnet++ library for end-to-end performance evaluation of 5g networks," *IEEE Access*, vol. 8, pp. 181 176–181 191, 2020.
- [23] C. Sommer, D. Eckhoff, A. Brummer, D. S. Buse, F. Hagenauer, S. Joerer, and M. Segata, "Veins: The open source vehicular network simulation framework," *Recent Advances in Network Simulation: The OMNeT++ Environment and its Ecosystem*, pp. 215–252, 2019.
- [24] N. R. Goodman, "Statistical analysis based on a certain multivariate complex gaussian distribution (an introduction)," *The Annals of mathematical statistics*, vol. 34, no. 1, pp. 152–177, 1963.